

FLOOR PLAN

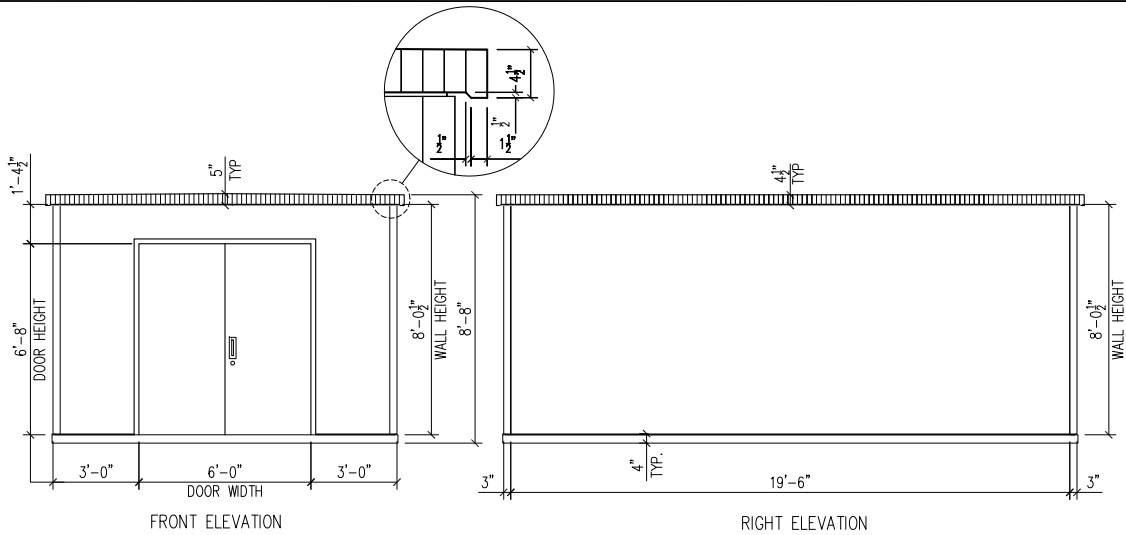

FRONT ELEVATION

RIGHT ELEVATION

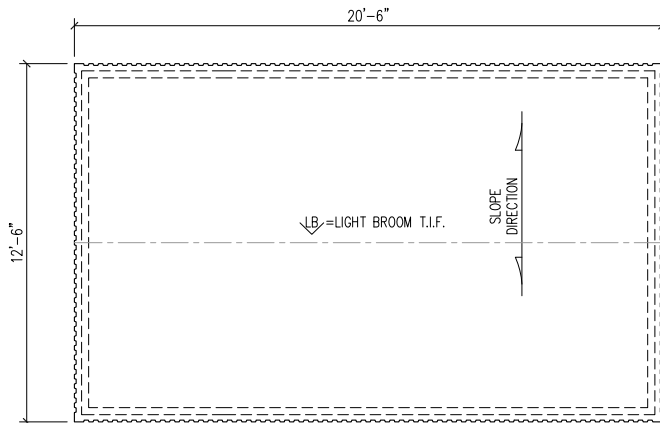

ROOF PLAN

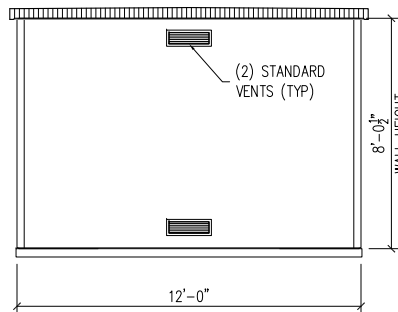

REAR ELEVATION

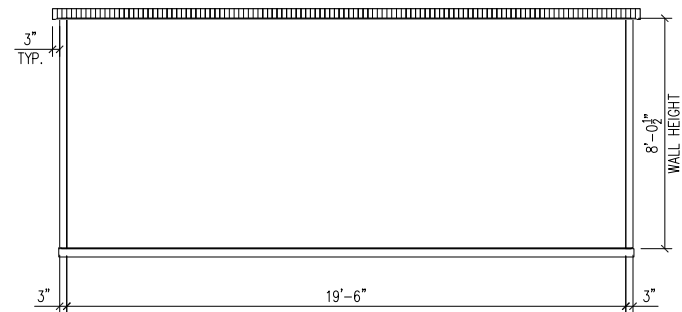

LEFT ELEVATION

NOTE: FINISH OPTIONAL, VARIOUS FINISHES ARE AVAILABLE

- EASI-BRICK
- EXPOSED AGGREGATE
- BROOM
- OTHER: \_\_\_\_\_

- GENERAL NOTES:
- ALL REQUIRED OPENINGS FOR ELECTRIC, MECHANICAL, LOUVERS, ETC. MUST BE SIZED AND LOCATED BY BUYER ON THIS DRAWING (OPENING SIZES AND LOCATIONS MAY HAVE TO BE ALTERED IF THEY INTERFERE WITH CONNECTIONS OR REINFORCING)
  - ALL VIEWS ARE FROM EXTERIOR
  - A SIGNED COPY MUST BE RETURNED BEFORE BUILDING CAN BE RELEASED FOR PRODUCTION

MESSAGE CENTER	
BUILDING FINISH	TO BE SELECTED
BUILDING STAIN	-
DOOR COLOR	-
BUILDING WEIGHT	-
CUSTOMER APPROVAL	
APPROVED BY:	DATE:

**EASI-SET® WORLDWIDE**  
**SET**  
 5119 Callett Rd. • Midland, VA 22728 • info@EasiSet.com  
 WWW.EasiSet.com • 800-547-4045 • Fax 540-439-2541

DATE	DESCRIPTION	INT.	REV.
-	-	-	1
-	-	-	2
-	-	-	3
-	-	-	4
-	-	-	5

PROJECT: 12'X20'X8' STD EASI-SET BUILDING  
 ADDRESS \_\_\_\_\_  
 CITY STATE \_\_\_\_\_  
 CONTRACTOR: CONTRACTOR \_\_\_\_\_

BUILDING LAYOUT

JOB # \_\_\_\_\_

DRAWN BY \_\_\_\_\_  
 WCR

CHECK BY \_\_\_\_\_  
 ESW

ISSUE DATE \_\_\_\_\_  
 03.28.14

SHEET LAYOUT

BUILDING LAYOUT